



Rotary Valves SR straight drop

Engineered to last

FOR POOR FLOWING PRODUCTS

The SR range is designed to handle poor flowing products as it is made without any reduction in cross section in the inlet or outlet and with oversized rotors to allow products to enter and exit the valve easily.

The SR units are made as standard with a round inlet and square outlet (this can be reversed) to make a simple connection between a round silo and square downstream equipment.



HIGHLY CONFIGURABLE

The rotor is available with many different configurations including square tip, friction relieved, wear plate, polyurethane, spring steel and closed end.

We can also polish and scallop the pockets to help the product discharge easily.

The rotors are all carefully machined to give the tightest possible clearance for each particular product meaning less leakage and a longer wear life before the clearances are too large.

We can fit chain or direct drives, and for high temperature applications extend the drive, use carbon lubricated or water cooled bearings and high temperature, gas purged shaft seals.

ATEX CERTIFICATION

The SR range is certified by Basseefa for use with explosive products, both as equipment and as a protective device.

As equipment, the valves are suitable for use with an internal zone 20 atmosphere where an explosive mixture is constantly present. Where explosion isolation is required, they have been tested to 10 bar with St2 category dusts.

	Internal	External
Zone 0/20	✓	✗
Zone 1/21	✓	✓
Zone 2/22	✓	✓
APD	✓	✗

LEAK FREE MECHANICAL SHAFT SEALS

With traditional seals the product pushes past packings and wear the shaft and even the body behind hard facings can wear out. Used for over 25 years, MID's unique mechanical shaft seals are leak tight and maintenance free, dramatically reducing maintenance costs and improving site housekeeping.

Eliminate all repetitive, leaking shaft maintenance

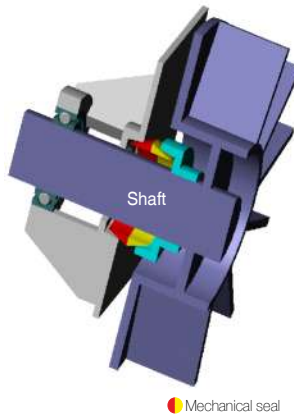

- Have no loss of product
- Immediately improve housekeeping and health and safety standards
- Eliminate compressed air purge costs
- Extend bearing life

Midland Industrial Designers Limited

Common Lane, Watnall, Nottingham, England NG16 1HD
T: (+44)(0)115 9382154 F: (+44)(0)115 9386315 E: enquiry@mid.uk.com
Manufacturers of powder handling equipment since 1959

www.mid.uk.com



Butterfly



Rotary

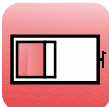

Slide



Knifegate



Diverter



Dyris



Ceramic



Specials



Sifter



Seals



Rotary Valves

SR straight drop

Engineered to last

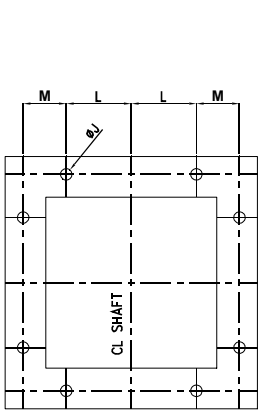

SR 190, 250, 320

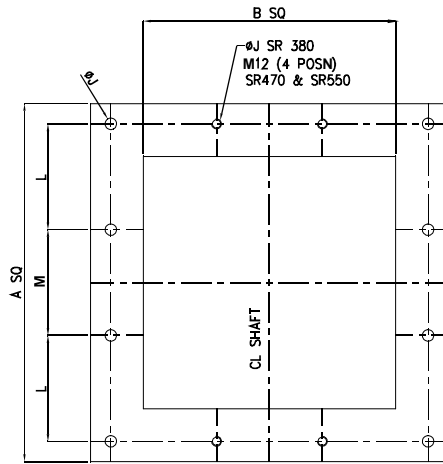

SR 380, 470, 550

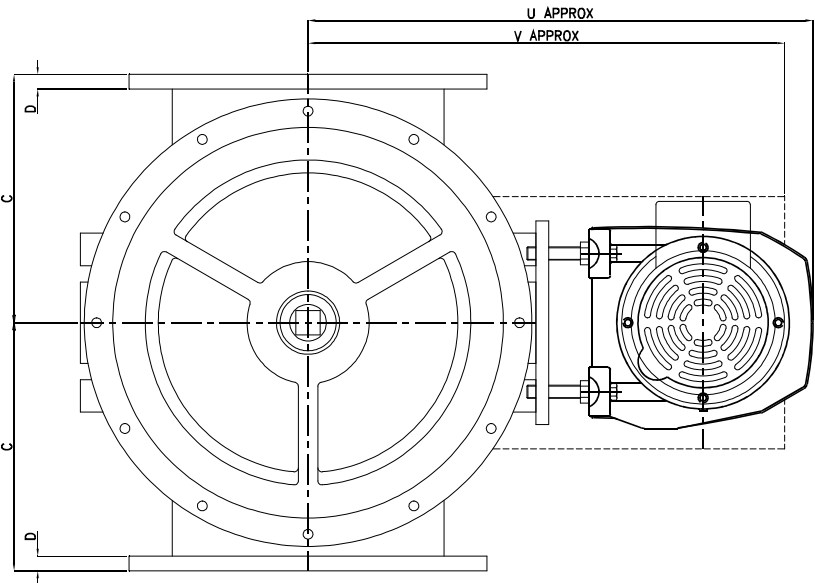
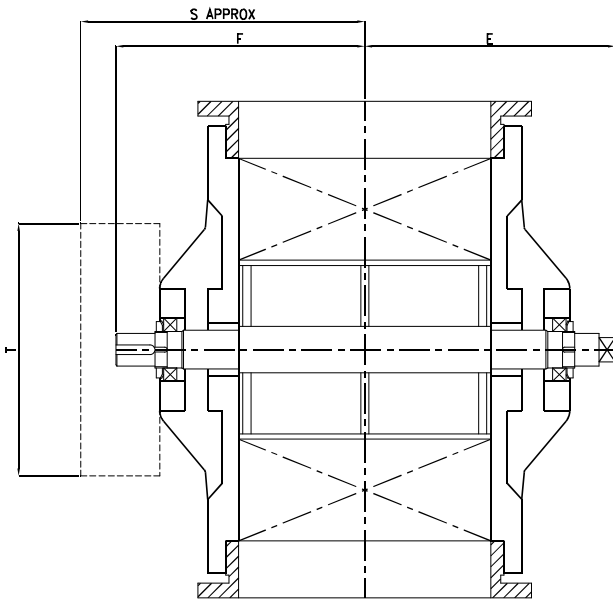
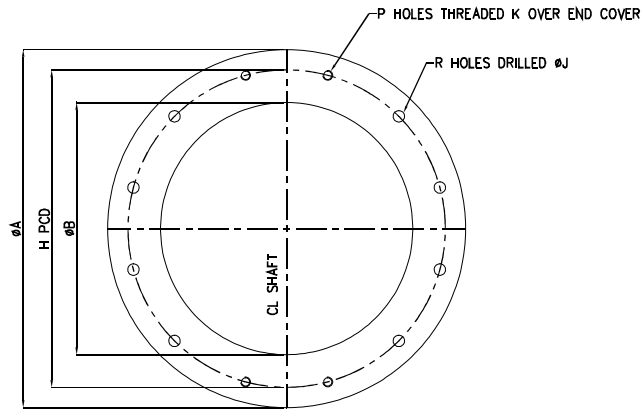

TYPE	A	B	C	D	E	F	G	H	J	K	L	M	N	P	R	S	T	U	V	Capacity	
																				ft ³ /rev	l/rev
190	200	130	130	10	185	215	22	174	12	M10	57	30	6x6	2	4	255	200	345	315	0.1	2.8
250	260	165	165	10	205	265	30	224	14	M12	65	47	8x7	2	4	305	210	415	385	0.23	6.6
320	310	205	205	12	230	265	35	266	14	M12	80	53	10x7	2	6	305	270	515	485	0.48	13.5
380	360	255	255	15	260	340	35	310	14	M12	100	110	10x7	4	8	380	310	560	530	0.78	22.2
470	440	305	305	18	258	306	40	390	14	M12	130	130	12x7	4	8	350	310	620	585	1.5	42.5
550	490	345	345	20	332	380	40	440	14	M12	145	150	12x7	4	8	367	310	660	625	2.3	65

Please note the type refers to the rotor diameter, not the inlet
Dimensions may vary depending on the options selected

Midland Industrial Designers Limited

Common Lane, Watnall, Nottingham, England NG16 1HD
T: (+44)(0)115 9382154 F: (+44)(0)115 9386315 E: enquiry@mid.uk.com
Manufacturers of powder handling equipment since 1959

www.mid.uk.com

