

Engineered to last

GR STANDARD DESIGN TO 380mm

MID's gravity diverter valve is used to divert powders and granules falling under gravity, but can also be used in low pressure pneumatic conveying applications.

BESPOKE DESIGN TO 1000mm

Like most of MID's products, if the standard designs don't suit, then we can engineer a valve that does. This includes manufacturing valves with inlets up to 1000mm sq. but can also include a multitude of options from adding additional outlets, inspection and access hatches, diverting flap positional control and a variety of corrosion and wear resistant materials.

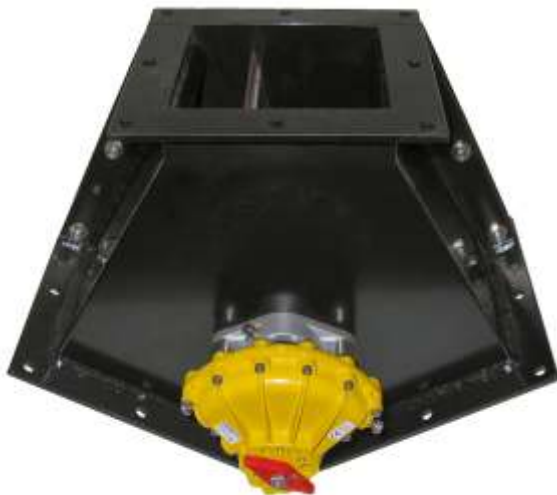

UNIQUE SELF ADJUSTING FLAP SEAL

Most diverter valves are manufactured with a soft seal on the flap to ensure product is conveyed in the intended direction and doesn't leak.

In applications with a high cycling frequency, this can cause premature wear of the seal allowing product to ingress through the gap.

MID's diverting vanes are manufactured from solid steel and feature three spring loaded, self adjusting seals, that not only seal the vane itself, but also the back of the shaft that the vane is mounted on.

ATEX CERTIFICATION

The GR range can be configured with ATEX Zone 22 certification

	Internal	External
Zone 0/20	✗	✗
Zone 1/21	✗	✗
Zone 2/22	✓	✓

STANDARD MODELS AND FEATURES

- Y type, with 2 off 30° outlets
- Straight through with a 30° divert
- Straight through with a 45° divert
- Custom sizes and angles to order

Standard features

- Heavy duty fabricated steel plate body
- Wear resistant polyurethane tip seal
- 2 off self adjusting, spring loaded vane seals
- 1 off self adjusting, spring loaded back shaft seal
- Sealed for life ball bearings
- Manual, pneumatic or electric actuation

Options

- Manual, pneumatic or electric actuation
- Exotic materials of construction
- ATEX certification
- Pressure shock resistant
- Three way



Butterfly



Rotary



Slide



Knifegate



Diverter



Dyris



Ceramic



Specials

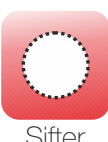

Sifter



Seals

Midland Industrial Designers Limited

Common Lane, Watnall, Nottingham, England NG16 1HD
 T: (+44)(0)115 9382154 F: (+44)(0)115 9386315 E: enquiry@mid.uk.com
 Manufacturers of powder handling equipment since 1959

www.mid.uk.com

Engineered to last

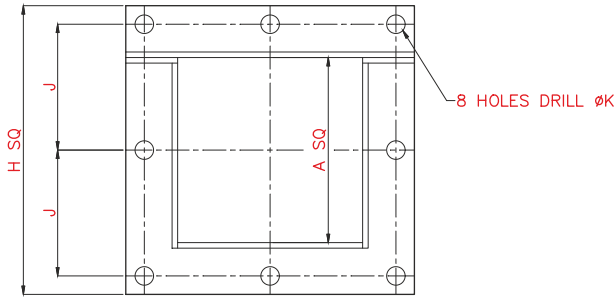

Flange 100 to 250

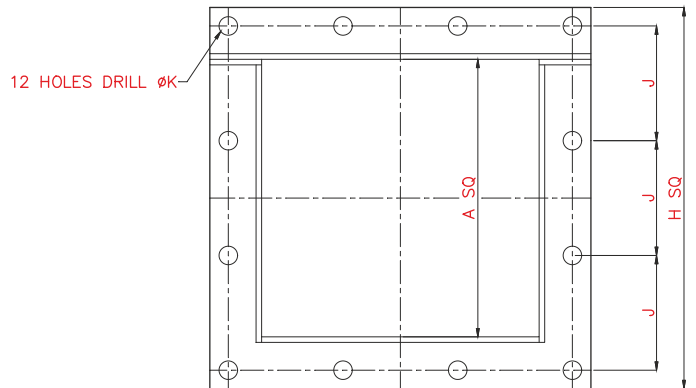

Flange 300 and above

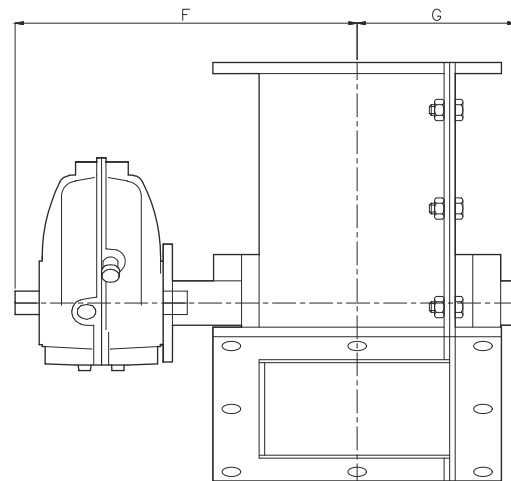
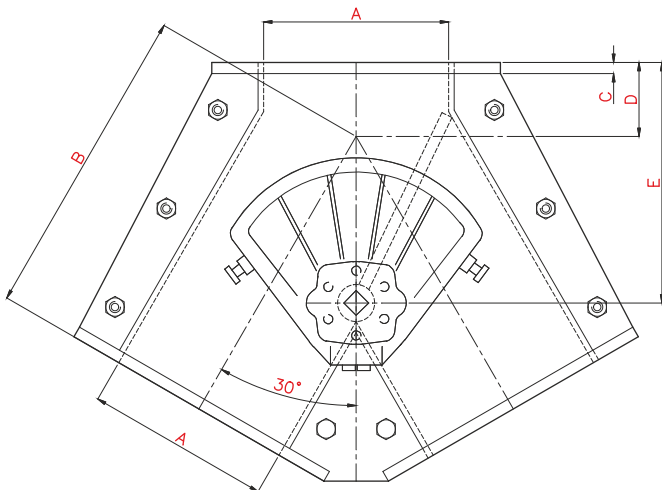

Size A	B	C	D	E	F	G	H	J	K
100	170	6	40	130	197	89	156	68	10
150	240	6	60	200	224	116	222	98	10
200	300	10	76	265	306	144	286	128	12
250	360	10	95	335	332	170	340	154	17
300	430	12	117	403	409	204	412	124	17
380	500	12	160	530	451	246	496	152	17

Standard sizes shown. Custom sizes made to suit.
 Available as a straight through version.
 Also available with a manual hand lever.

Midland Industrial Designers Limited