

Engineered to last

STANDARD DESIGN 150-500mm

The MV range is designed to fit between standard, off the shelf flanges to make installation as easy as possible. For larger or smaller sizes, we fabricate the valves to fit.

If you need us to replace another manufacturers valve with slightly different dimensions, we can fabricate the valve so that our replacement will slot in exactly where the other unit was.

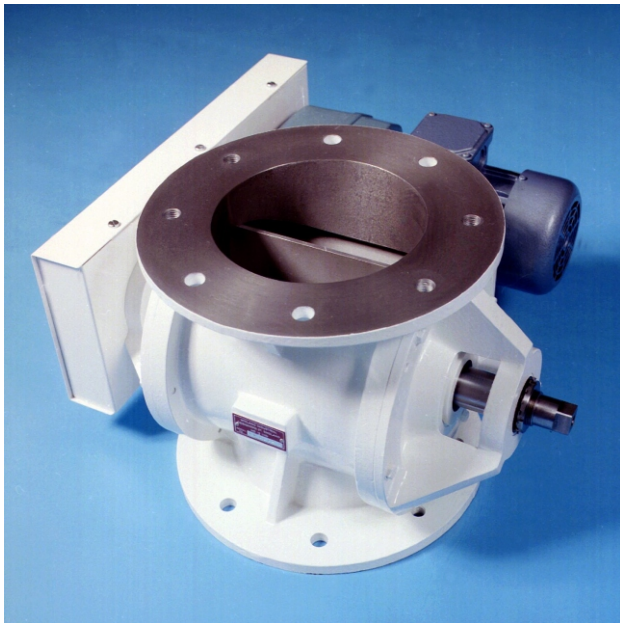

HIGHLY CONFIGURABLE

Rotor:

- Square tip
- Friction relieved
- Wear plate
- Polyurethane
- Spring steel
- Closed end
- Replaceable tips

Body:

- Round
- Square
- Twin outlet
- Round in - square out
- MVX wear plate
- Replaceable liners
- Odd shapes

LIFE EXPECTANCY X 4?

Compared to a cast iron or carbon steel valve, adding 400 wear plate to the rotor and body extends the valve life, by between 3 to 4x, but only costs approximately 30% more.

See our MVX range for more details.

ATEX CERTIFICATION

The MV range is certified by Basseefa for use with explosive products, both as equipment and as a protective device.

As equipment, the valves are suitable for use with an internal zone 20 atmosphere where an explosive mixture is constantly present. Where explosion isolation is required, they have been tested to 10 bar with St2 category dusts.

	Internal	External
Zone 0/20	✓	✗
Zone 1/21	✓	✓
Zone 2/22	✓	✓
APD	✓	✗

MECHANICAL SHAFT SEALS

With traditional seals the product pushes past packings and wear the shaft and even the body behind hard facings can wear out. Used for over 25 years, MID's unique mechanical shaft seals are leak tight and maintenance free, dramatically reducing maintenance costs and improving site housekeeping.

GUARANTEED - NO LEAKAGE

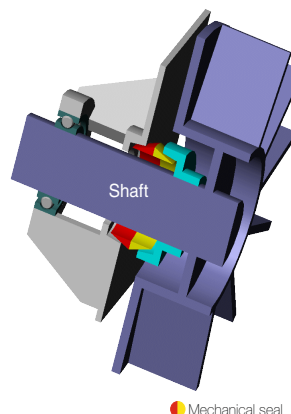

- Zero Maintenance
- Have no loss of product
- Immediately improve housekeeping and health and safety standards
- Eliminate compressed air purge costs
- Extend bearing life



Butterfly



Rotary



Slide



Knifegate



Diverter



Dyris



Ceramic



Specials



Sifter



Seals

Midland Industrial Designers Limited

Engineered to last

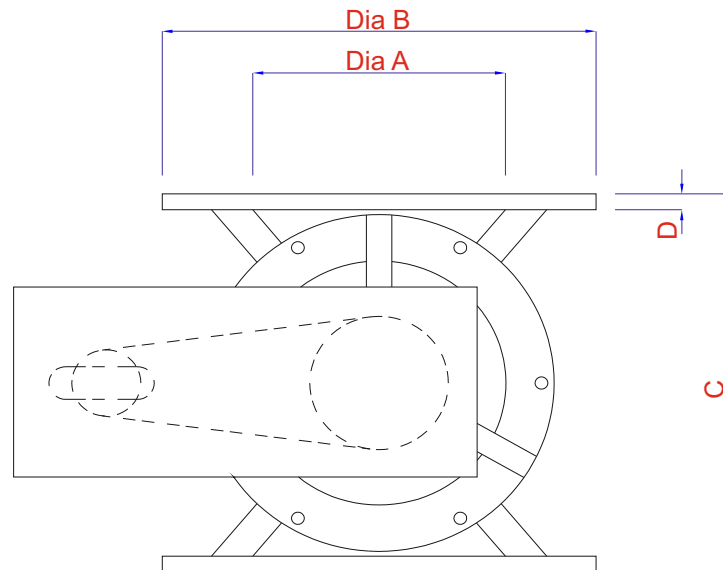
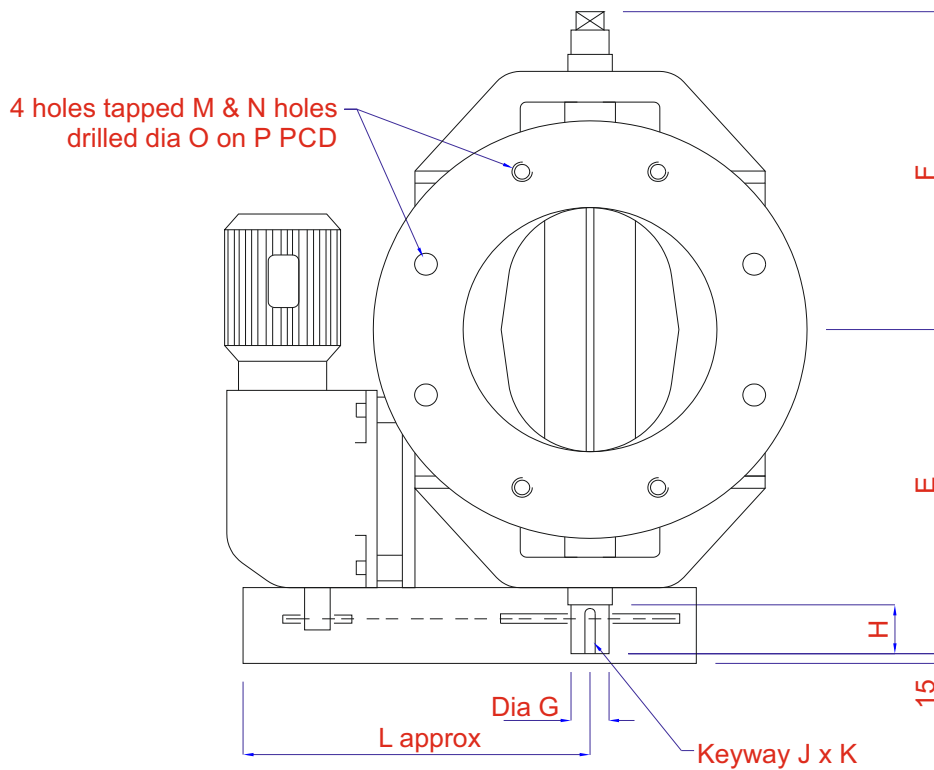

Size	A	B	C	D	E	F	G	H	J	K	L	M	N	O	P	ft ³ /rev	l/rev	kW
150	150	280	250	12	228	223	22	35	6	3.5	298	16	4	18	225	0.088	2.5	0.12
200	200	342	310	13	265	260	30	40	8	4	362	16	4	18	280	0.22	6.2	0.37
250	250	406	380	15	292	287	30	40	8	4	395	16	8	18	335	0.50	12.0	0.55
300	300	482	450	18	352	337	35	55	10	5	480	20	8	23	395	0.73	20.6	0.75
350	350	533	520	18	377	362	35	55	10	5	520	20	8	23	445	1.15	32.5	1.10
400	400	596	580	20	414	399	40	55	12	5	585	20	12	23	495	1.75	49.5	1.50
500	500	698	670	20	465	450	50	55	12	5	690	20	16	23	600	3.24	91.7	2.20

Larger valves designed and built to order

Midland Industrial Designers Limited

Engineered to last

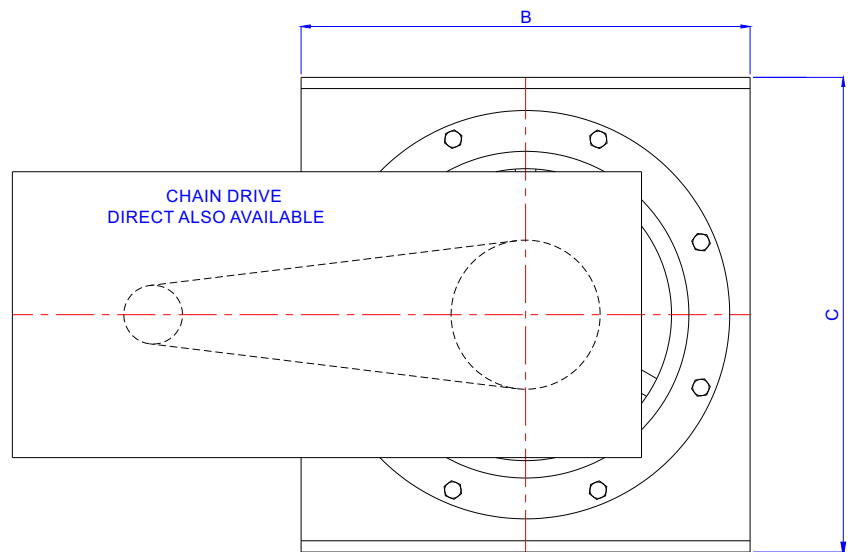
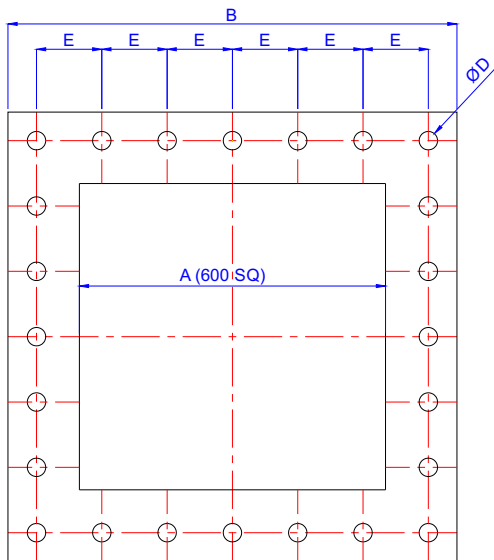
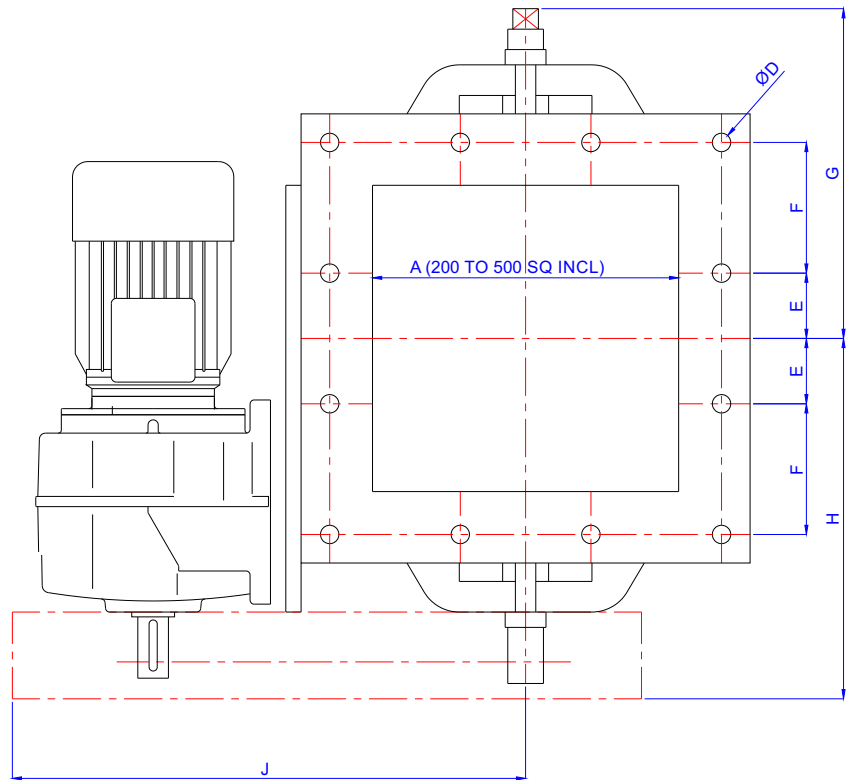
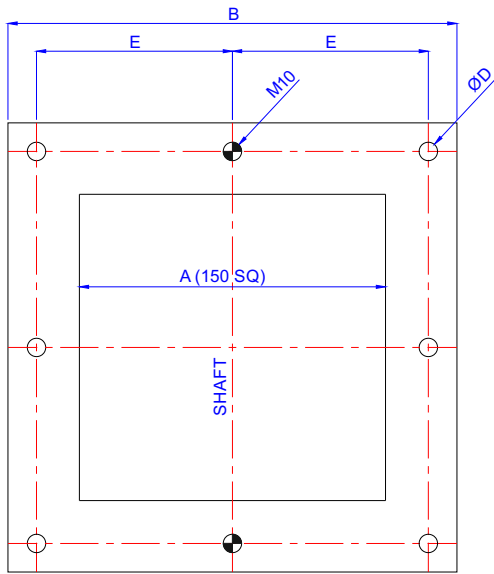

SIZE A	B SQ	C	D	E	F	G	H	J	l/rev	kW
150	280	250	12	115	-	213	233	354	2.5	0.12
200	300	310	12	45	90	260	280	400	6.2	0.37
250	370	388	18	54	108	275	292	450	12.2	0.55
300	440	465	18	64	128	323	353	503	20.6	0.75
350	490	520	14	75	145	348	382	536	32.5	1.1
400	550	580	18	85	170	385	425	585	49.5	1.5
450	600	640	18	90	180	378	419	620	61	1.5
500	650	670	18	100	200	447	515	635	92	2.2
600	800	770	18	148	-	633	654	685	140	3.0

Larger valves designed and built to order

Midland Industrial Designers Limited