



Engineered to last

STANDARD DESIGN TO 6TPH

Used mainly, but not exclusively, within the food industry, sifters and conditioners remove contaminants and produce a homogeneous, aerated product discharge.

Commonly used with bakery flour and other ingredients, the units maximum capacity depends on the product itself and the degree to which it needs to be conditioned. In many cases, this will be established empirically.



TWIN CHAMBER DESIGN TO 12TPH

Product enters the sifter through the inlet cone and a small screw pushes the product along and into the sifting chamber. The high speed rotating paddle forces the product outwards and through the perforated sifting basket.

Unlike other sifters, we use solid, perforated plate rather than much weaker mesh, and this means that any stray nuts, bolts or general contaminants that find their way into the chamber won't cause any damage.

MID offers the FS100 single chamber unit that can deliver up to 6tph and the twin FS102 twin chamber version with a maximum throughput of 12tph, depending on product characteristics.

ATEX CERTIFICATION

The high speed of the sifting chamber prohibits us from offering ATEX certification internally, although externally we can offer Zone 22 certification.

	Internal	External
Zone 0/20	✗	✗
Zone 1/21	✗	✗
Zone 2/22	✗	✓
APD	✗	✗

HIGHLY CONFIGURABLE

Standard specification includes an aluminium body with a nickel plated, mild steel paddle and sieve, with an IP55 motor, but fully or partial stainless steel models are available on request.

In addition to this, there are a number of other options available including;

- different screen sizes and perforations
- wedge wire screens
- inlet swivel - discharge into multiple hoppers
- dust suppressing outlet skirt
- inspection panels
- quick removable rotor/paddle
- fan assisted filter vent unit
- inlet cyclone
- pneumatic conveying version - sift "in-line"
- condition monitoring extras/sensors
- ATEX certification to Zone 22 external



Midland Industrial Designers Limited

Common Lane, Watnall, Nottingham, England NG16 1HD
T: (+44)(0)115 9382154 F: (+44)(0)115 9386315 E: enquiry@mid.uk.com
Manufacturers of powder handling equipment since 1959

www.mid.uk.com





FS 100/102 High Speed Sifter

Engineered to last

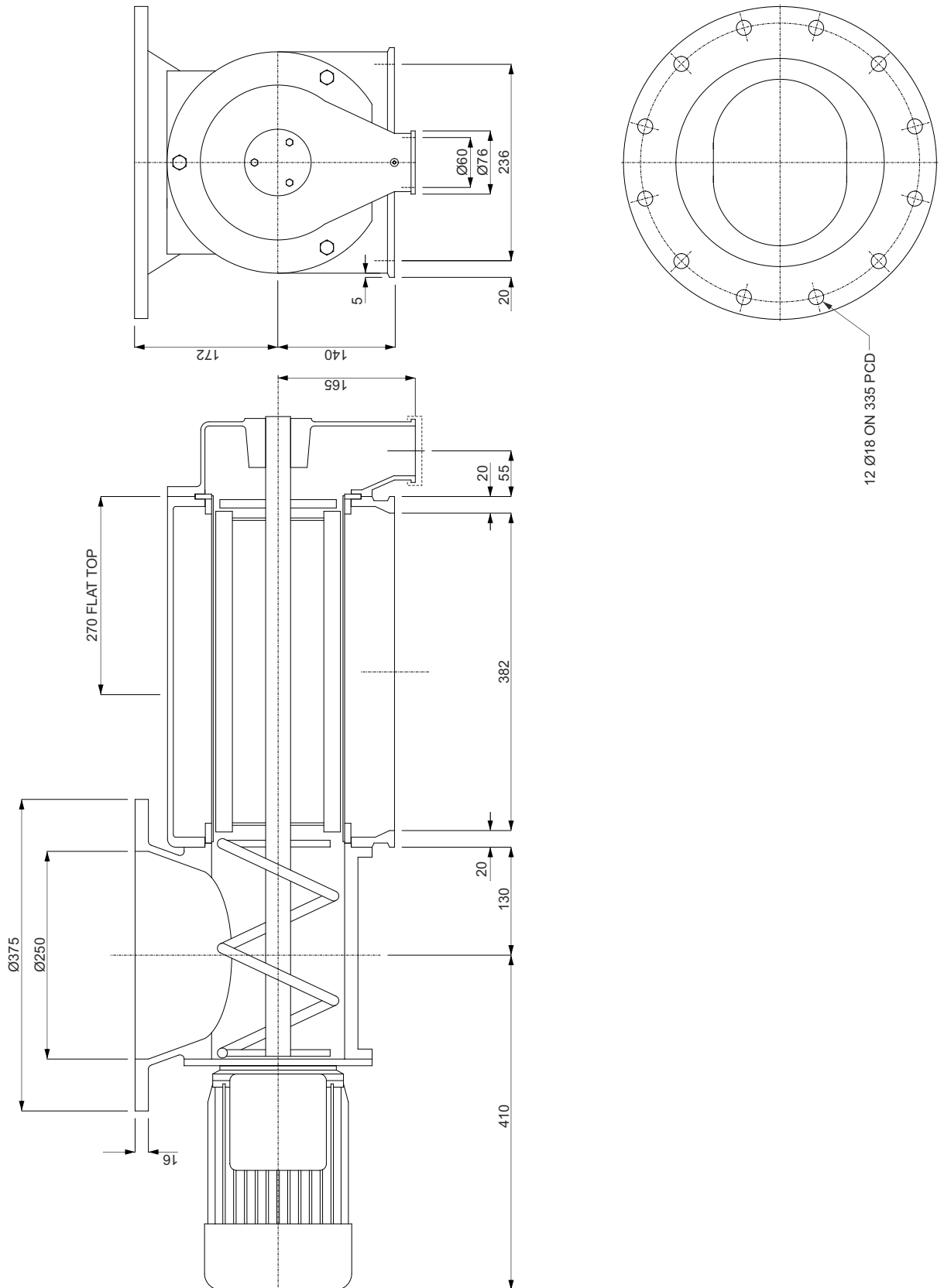

Midland Industrial Designers Limited

Common Lane, Watnall, Nottingham, England NG16 1HD
T: (+44)(0)115 9382154 F: (+44)(0)115 9386315 E: enquiry@mid.uk.com
Manufacturers of powder handling equipment since 1959

www.mid.uk.com

