



Butterfly Valves WBV wafer pattern

Engineered to last

WBV STANDARD DESIGN TO 500mm

MID's wafer style butterfly valves can be used across a variety of applications including providing a tight shut off for powders and granules in a silo or hopper, to throttling pneumatic conveying air or being used in fume extraction systems.

Unlike the BV range, the WBV fits in-between existing flanges - see sheet overleaf for compatibility with standard flanges



UNIQUELY DESIGNED VANE SEAL

Unlike other butterfly valves that typically have a seal in the body that the vane closes against, MID's unique BV design moves the seal from the body to the vane itself, meaning that seal changes can be made without removing the valve, saving time and reducing process stoppages.



WEAR RESISTANCE? GRANULES?

We can also remove the vane seal completely leaving a close tolerance clearance of no more than 0.008" which is sufficient to halt the flow of products with granules that exceed this dimension.

We can then manufacture the vane and body from 400 wear plate and create a valve with 4X the life of a standard cast iron valve with no soft seat to wear away or seal to replace.

ATEX CERTIFICATION

The WBV range can be offered with Zone 21 and 22 internal and external ATEX certification

	Internal	External
Zone 0/20	✗	✗
Zone 1/21	✓	✓
Zone 2/22	✓	✓
APD	✗	✗

HIGHLY CONFIGURABLE

Standard specification includes;

- cast iron, carbon steel, stainless or aluminium body and vane
- vane and shaft seals including Nitrile, Viton, EPDM and PTFE
- available with manual or infinite lock handles, pneumatic or electric actuation

Options include

- high temperature (800°C) gland packing
- exotic materials (Hastelloy, Kalrez)



Butterfly



Rotary

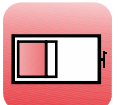

Slide



Knifegate



Diverter



Dyris



Ceramic



Specials



Sifter



Seals

Midland Industrial Designers Limited

Common Lane, Watnall, Nottingham, England NG16 1HD
T: (+44)(0)115 9382154 E: enquiry@mid.uk.com
Manufacturers of powder handling equipment since 1959

www.mid.uk.com





Butterfly Valves WBV wafer pattern

Engineered to last

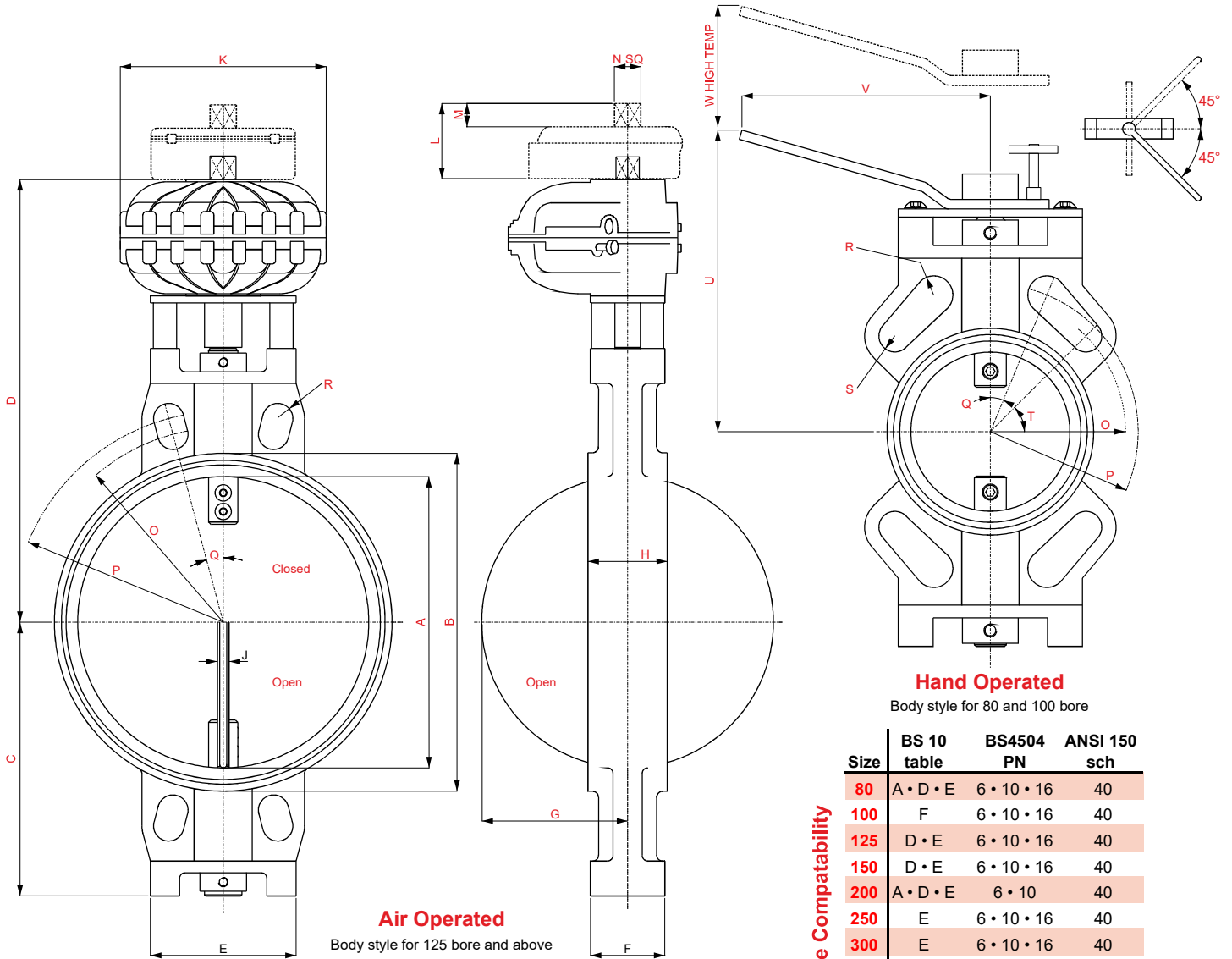

Flange Compatibility

Size	BS 10 table	BS4504 PN	ANSI 150 sch
80	A • D • E	6 • 10 • 16	40
100	F	6 • 10 • 16	40
125	D • E	6 • 10 • 16	40
150	D • E	6 • 10 • 16	40
200	A • D • E	6 • 10	40
250	E	6 • 10 • 16	40
300	E	6 • 10 • 16	40
350	D • E	6	20
400	-	6 • 10 • 16	20
450	E	-	20
500	-	6 • 10 • 16	20

Size	Actuator											Switches												
	A	B	C	D	E	F	G	H	J	K	L	M	N	M	N	O (rad)	P (rad)	Q°	R	S	T°	U	V	W
80	80	110	121	207	116	34	40	44	6	113	62	12	9	10	8	75	80	22.5	10	10	45	190	180	75
100	100	130	135	233	116	36	50	48	8	136	64	13	9.5	20	16	85	93	22.5	12	10	45	205	180	75
125	125	155	148	246	116	38	62.5	50	8	136	64	13	9.5	20	16	100	108	22.5	11	-	-	218	180	75
150	150	180	160	258	116	46	75	52	8	136	64	13	9.5	20	16	112	121	22.5	11	-	-	230	180	75
200	200	240	190	335	125	58	100	60	10	178	64	20	16	20	16	140	150	22.5	11	-	-	280	285	140
250	250	290	235	406	125	64	125	68	10	178	64	20	16	20	16	167	181	15	13	-	-	325	285	140
300	300	350	270	452	160	70	150	76	12	227	64	26	19	20	16	197	216	15	14	-	-	390	365	160
350	338	388	295	477	160	70	175	76	12	227	64	26	19	20	16	222	240	15	15	-	-	415	365	120
400	390	440	337	556	178	70	200	86	12	294	80	31	25	25	25	247	270	33.75	15	-	-	477	450	120
450	442	492	380	599	222	88	225	100	12	294	80	31	25	25	25	275	292	33.75	16	-	-	520	450	120
500	488	538	410	629	222	88	250	120	12	294	80	31	25	25	25	300	325	45	17	-	-	550	450	120

Midland Industrial Designers Limited

Common Lane, Watnall, Nottingham, England NG16 1HD
 T: (+44)(0)115 9382154 E: enquiry@mid.uk.com
 Manufacturers of powder handling equipment since 1959

www.mid.uk.com

